

JMILLOCK[®]

J-CARA[®]

INSTALLATION MANUAL

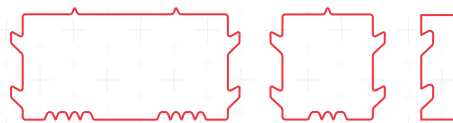

US PATENT: 9,453,341
INTERNATIONAL PATENTS PENDING



THE U-CARA[®] ADVANTAGE

- Easy-to-learn system
- Easy-to-handle lightweight components
- Interchangeable components for seamless integration with other Unilock products
- One platform to create different looks
- Dimensional accuracy for precise installation

CONTENTS

Components.....	2
Typical Projects.....	3-4
Design.....	5
Planning.....	6
Calculating.....	7
Base Preparation.....	8
Wall Cross Sections (Typical).....	9-10
Typical Assembly.....	11-15
Seat Walls.....	16
Garden Borders.....	17
Steps.....	18
Raised Patios.....	19
Pillars.....	20
Grill Island.....	21
Fire Pit.....	22
Engineering.....	23-26

COMPONENTS

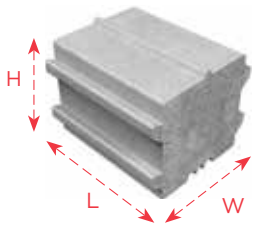

Standard Sure Track[®] Backer

6" H x 8" L x 6" W
15 cm x 20 cm x 15 cm

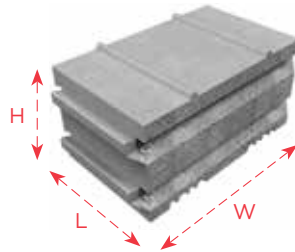

Large Sure Track Backer

6" H x 7" L x 12" W
15 cm x 17.5 cm x 30 cm



Universal Base Unit

2" H x 19" L x 14" W
5.5 cm x 48.2 cm x 35.5 cm



Universal Coping

2.75" H x 19" L x 14" W
7 cm x 48.2 cm x 35.5 cm



U-Cara[®] Standard Fascia Panel

6" H x 18.5" L x 2.36" W
15 cm x 46.6 cm x 6 cm



U-Cara Standard Fascia Half Panel

6" H x 9.25" L x 2.36" W
15 cm x 23.3 cm x 6 cm



U-Cara 3" Panel

3" H x 9.25" L x 2.36" W
7.5 cm x 23.3 cm x 6 cm



U-Cara Closed-End Fascia Corner Panel

6" H x 20.9" L x 2.36" W
15 cm x 53 cm x 6 cm

The U-Cara Multi-Face Wall System is a platform comprised of only a few components that provide a huge array of installation and design options.



Sure Track Corner Insert

L = 2" (5 cm)

All measurements are nominal.

WALLS

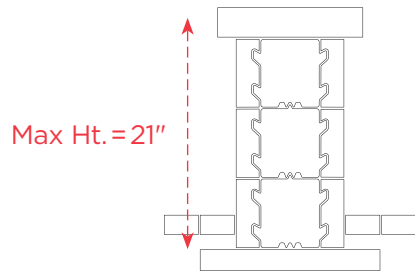

Seat Walls

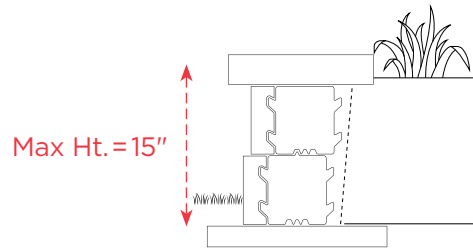

Garden Borders

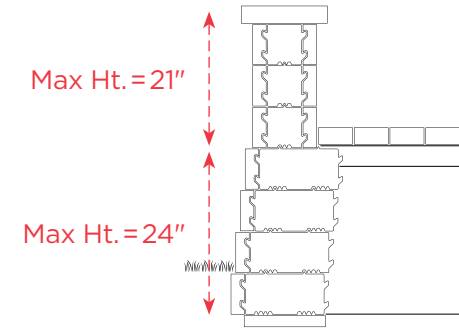

Raised Patios

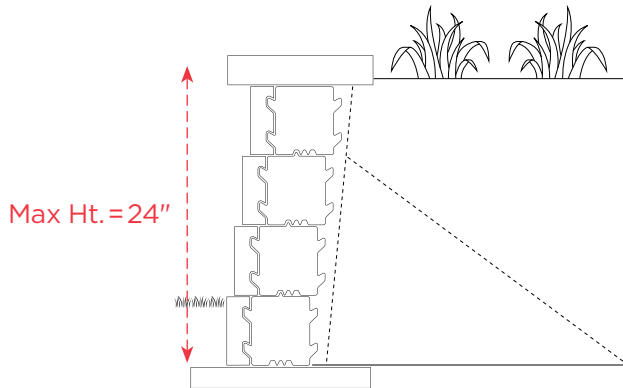

Planters/Walls (Under 24")

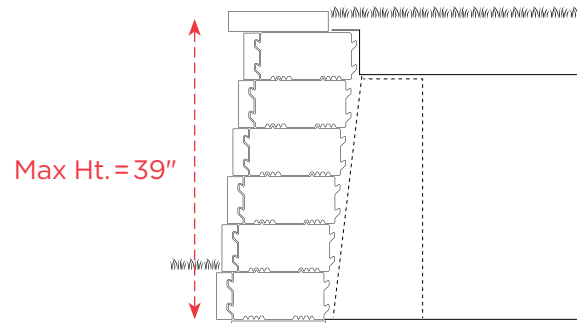

Walls (24" - 39")

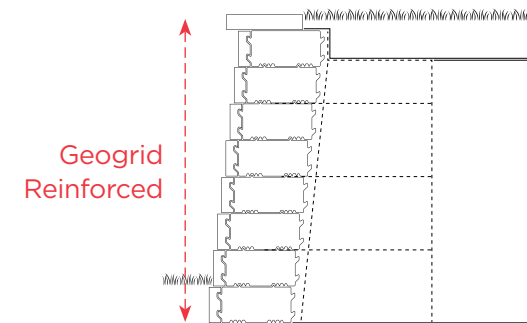

Walls (Over 39", see page 25)

Always observe retaining wall building codes. Large walls should always be reviewed by a professional engineer prior to construction.

LANDSCAPE FEATURES

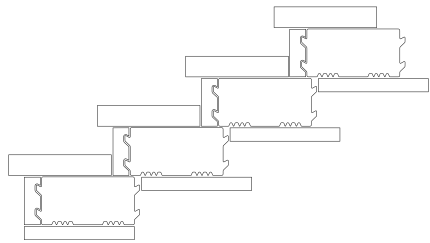

Steps

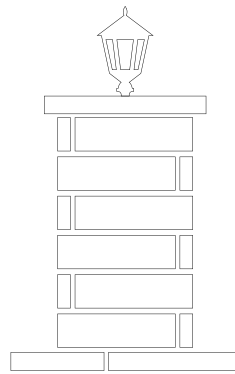

Pillars

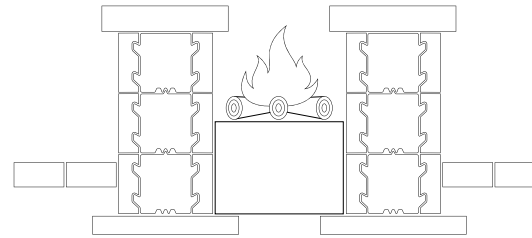

Fire Pits

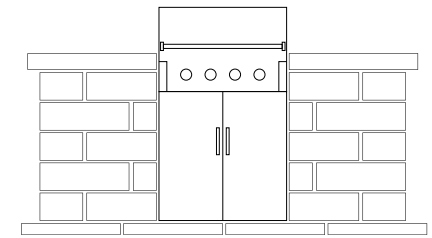

Grill Islands

Virtually any landscape wall or feature can be built using the U-Cara Multi-Face Wall System. U-Cara's dimensions, sizes and technology make it the most flexible and easy to install system on the market. This manual will illustrate how to construct some of the most common walls and features. The more you work with it, the more you'll discover U-Cara's application flexibility.

DESIGN

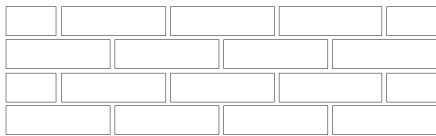

1/2 Running Bond

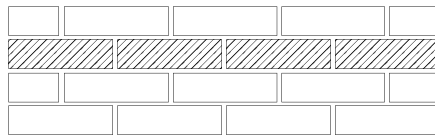

1/2 Running Bond with Linear Accents

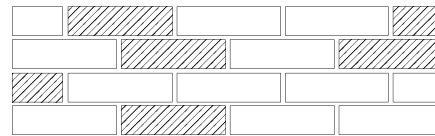

1/2 Running Bond with Random Accents

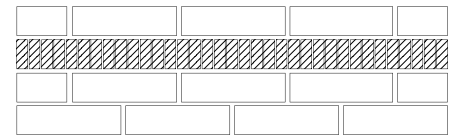

1/2 Running Bond with Paver Accents

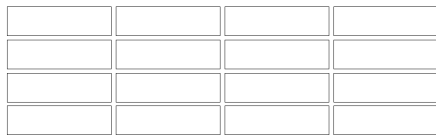

Stacked Bond

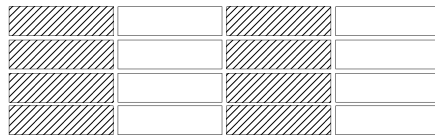

Stacked Bond with Accents

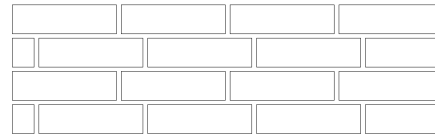

1/3 Running Bond

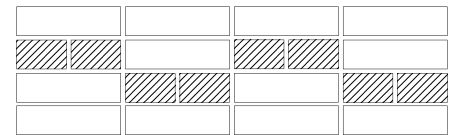

Mixed Bond

The U-Cara wall system is a patented wall system that gives you more design options for complete creative flexibility. That's because U-Cara Fascia Panels can be placed anywhere on the Sure Track® Backer Blocks, allowing for a variety of pattern, color and texture combinations not possible with other systems.

PLANNING

Always start with an in-depth consultation to better understand what your client is looking for. Learning about your client's budget, needs and aspirations will help you to design their outdoor space.

In practical terms, a good outdoor living space should always take in consideration things such as group size, traffic flow of people and proportional scale to the size of the home.

We recommend that you watch the **U-Cara Installation Video Series** at unilock.com for a first-hand look at an actual project installation.

PLANNING

Whether you are building a seat wall, pillar or grill island, plan your project with U-Cara Fascia Panel dimensions in mind. Remember, fewer cuts means faster installation.

- 1 Sketch your overall design concept.
- 2 Use CAD or Uvision 3D to lay out location and heights of features.
- 3 Optimize your design using fascia panel lengths.
- 4 Decide on location of lights, water and other utilities.
- 5 Calculate number of fascia panels and Sure Track® Backer Blocks.
- 6 Calculate base requirements.

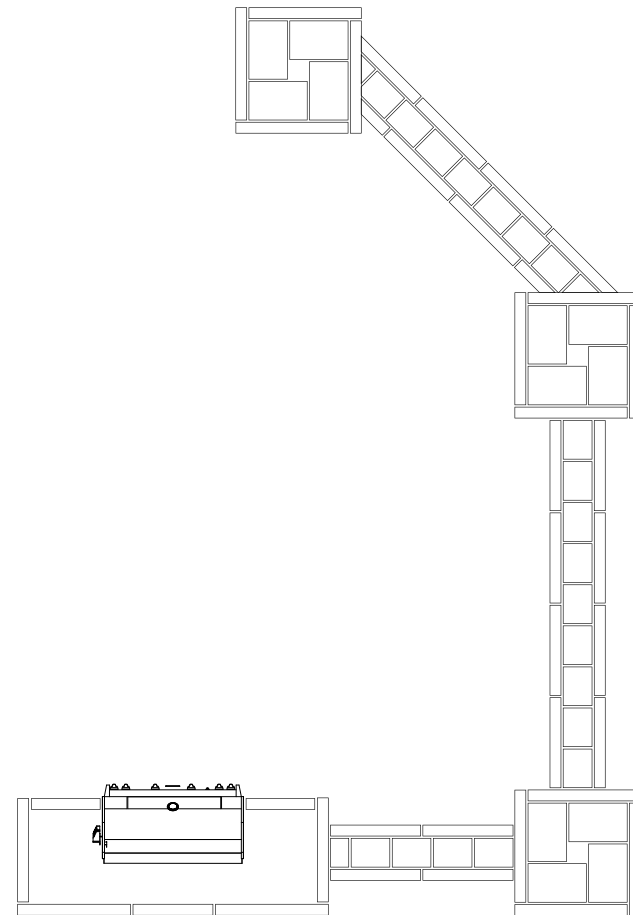

CALCULATE

CALCULATION EXAMPLE

The example below can help you calculate the number of U-Cara products needed for a pillar and wall project.

PILLARS:

- 4 Large Backer Blocks per layer = 24 units per pillar x 2 = 48 units total
- 4 Standard U-Cara Closed-End Corner Panels per layer = 24 units per pillar x 2 = 48 units total
- 2 Pillar Caps
- 96 Sure Track® Corner Inserts
- 8 Tubes of Concrete Adhesive (10 oz Approx.)

WALL:

- 9 Standard Sure Track Backer Blocks per layer = 27 units total
- 12 Standard U-Cara Fascia Panels per side = 24 units total
- 4 Universal Copping units

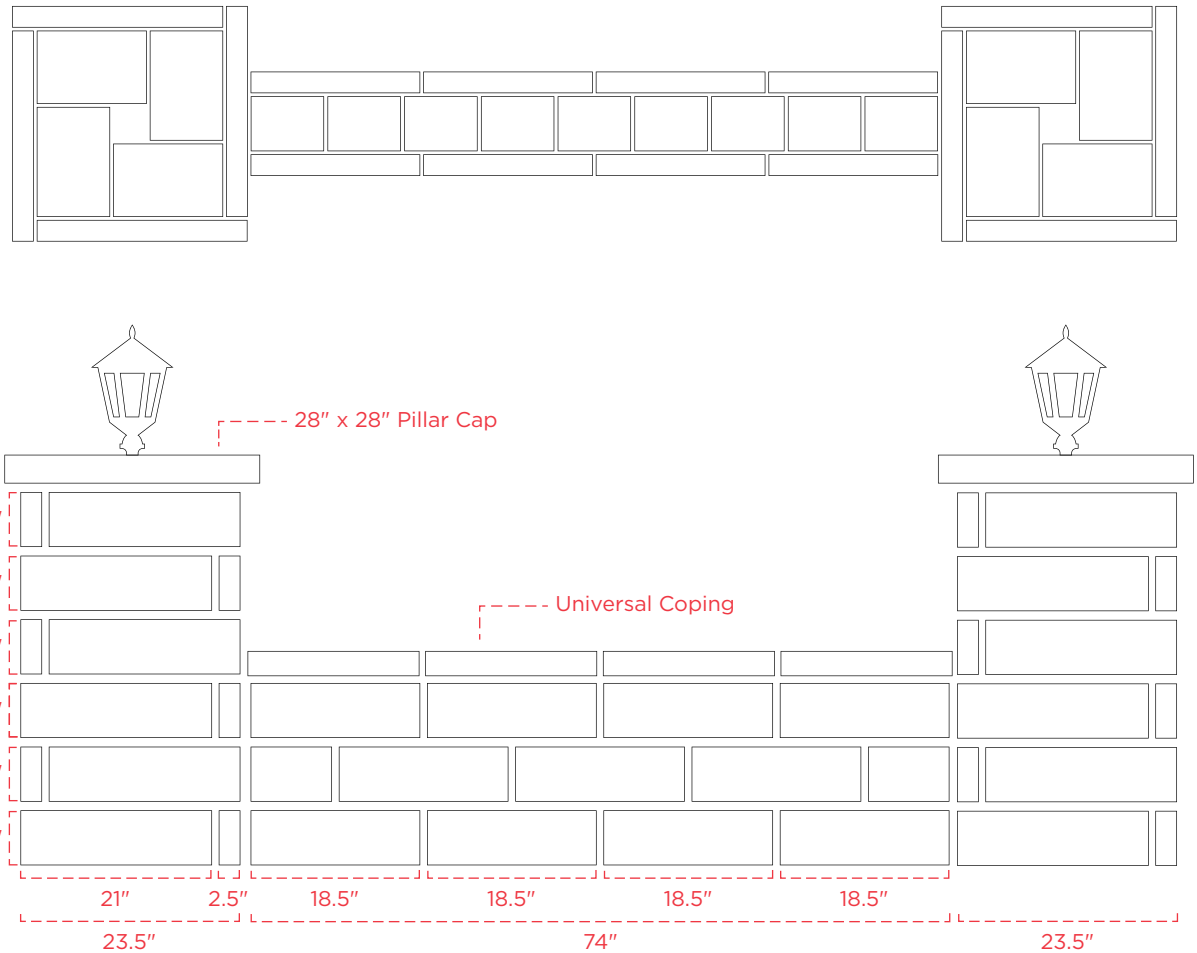

INSTALL

BASE PREPARATION

Base preparation for walls and pillars is standard for all Unilock wall systems. However, with U-Cara, we strongly recommend you use the Universal Base Unit as a leveling pad on top of the gravel base. This will significantly increase the speed of installation and maintain the long-term integrity of your project.

- 1 Excavate a trench with a minimum depth of 16" for walls and 24" for pillars.
- 2 The width of the trench should be twice the width of the wall unit.
- 3 Ensure that all topsoil is removed down to undisturbed subsoil.
- 4 Line the trench with Unilock DriveGrid™ or a permeable landscape filter fabric.
- 5 Place 4" to 8" of free draining gravel in the trench. (Open-graded gravel or typical road base is recommended.)
- 6 Walls generally should have one complete row of wall units below grade. However, for walls 12" or lower, a half block below grade is sufficient. Pillars should have a minimum of 2 courses of wall units below grade. Adjust your excavation accordingly.
- 7 Compact the gravel in the trench with a jumping jack, hand tamper or plate compactor.
- 8 Place and level the Universal Base Units on the gravel base at the appropriate height.

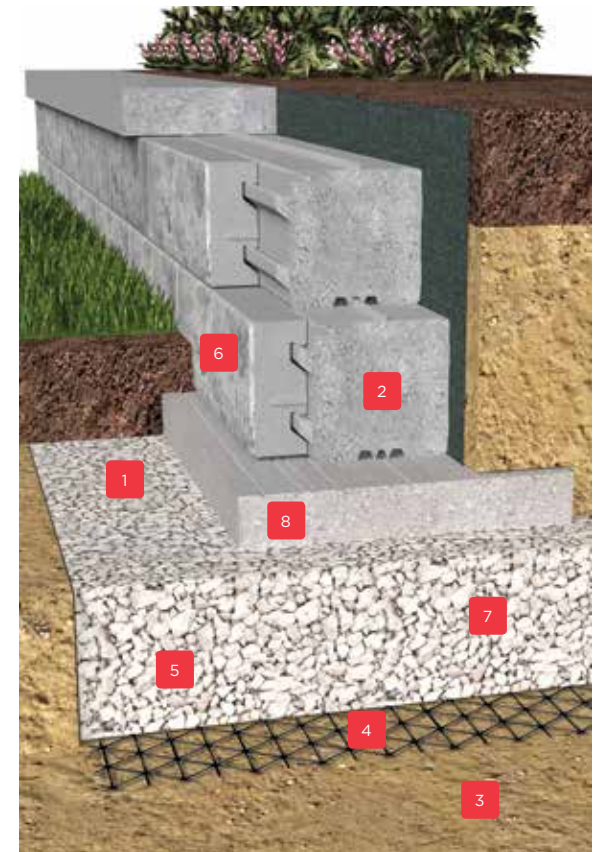

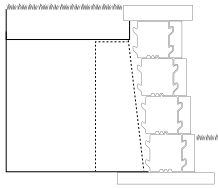

Gravity Wall
with Standard
Sure Track®
Backer Blocks

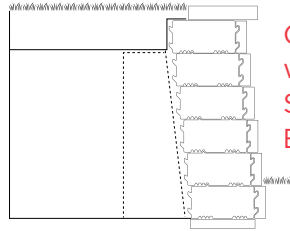

Gravity Wall
with Large
Sure Track®
Backer Blocks



GRAVITY WALL

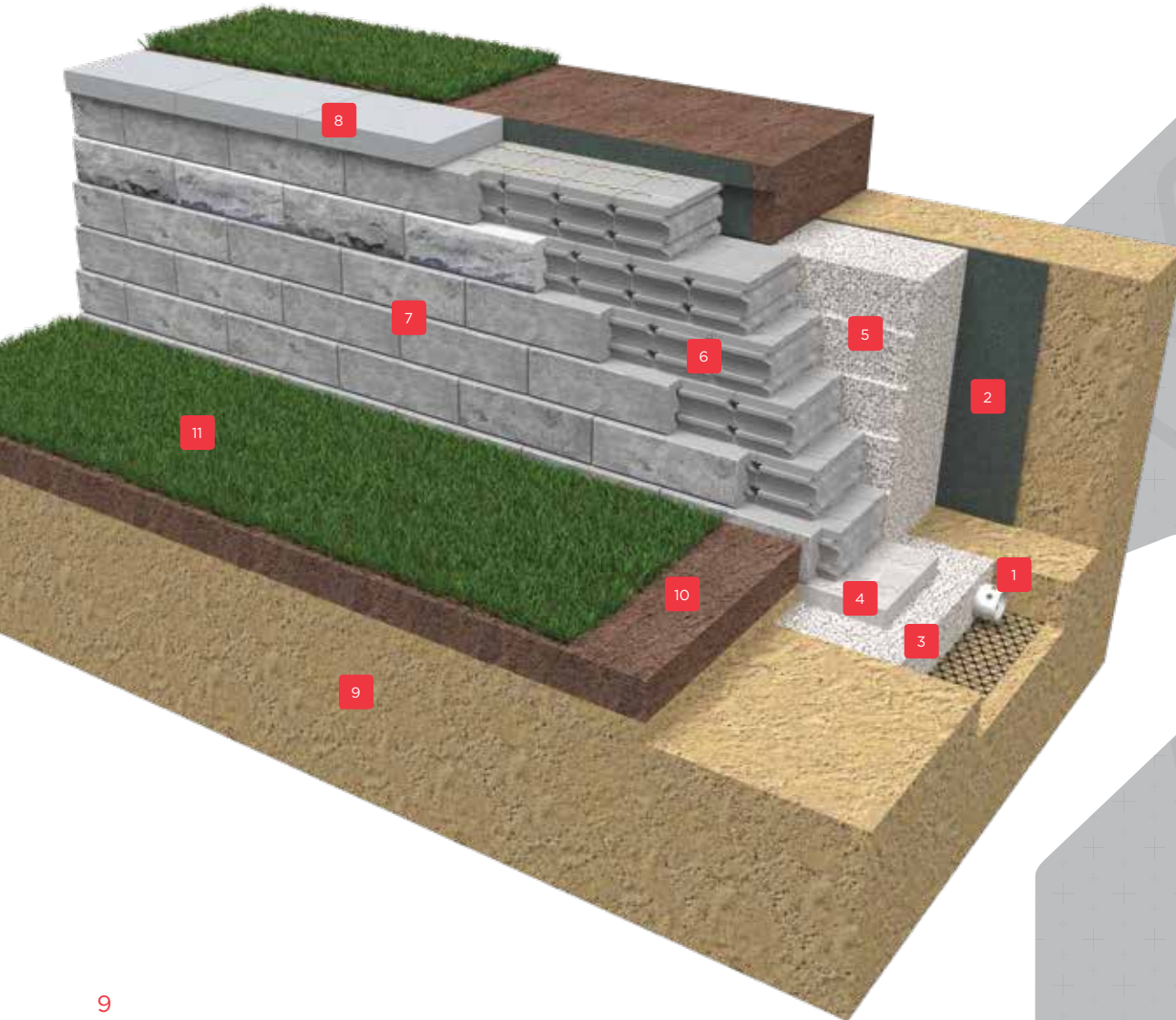

- 1 Perforated Drainage Pipe
- 2 Filter Fabric
- 3 3/4" Clear Stone (ASTM No. 57)
or Road Base (6" thick)
- 4 Universal Base Unit
- 5 3/4" Clear Stone (ASTM No. 57)
Backfill min. 12" wide
- 6 Large Sure Track Backer Block
- 7 U-Cara Fascia Panel
- 8 Coping
- 9 Subsoil
- 10 Topsoil
- 11 Turf



GEOGRID WALL

- 1 Perforated Drainage Pipe
- 2 Compacted Granular Fill as specified by engineer
- 3 3/4" Clear Stone (ASTM No. 57) or Road Base (6" thick)
- 4 Universal Base Unit
- 5 Approved Geogrid
- 6 Large Sure Track® Backer Block
- 7 U-Cara Fascia Panel
- 8 Filter Fabric
- 9 Coping
- 10 Subsoil
- 11 Topsoil
- 12 Turf

Geogrid Reinforced Wall with Large Sure Track® Backer Blocks

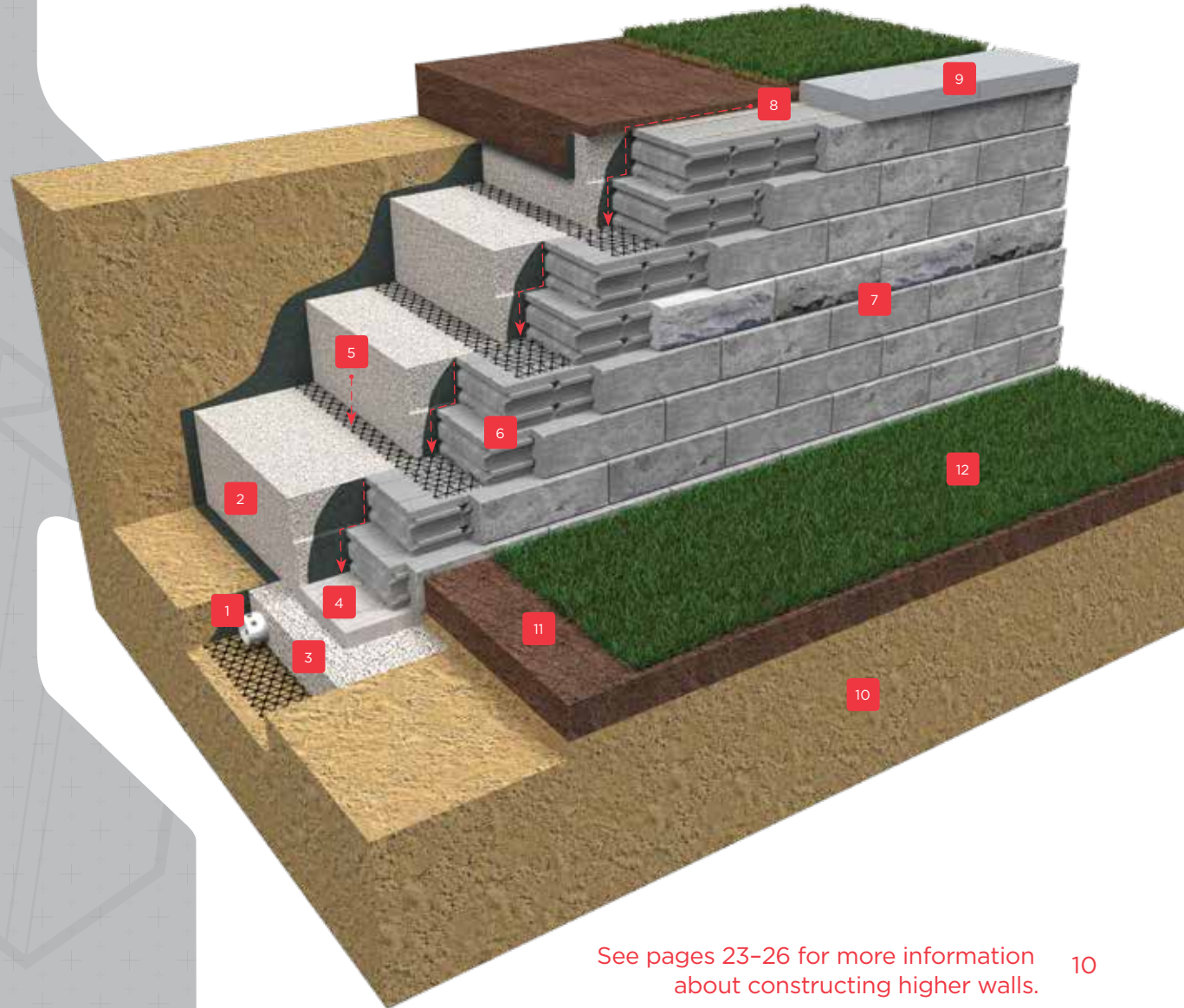
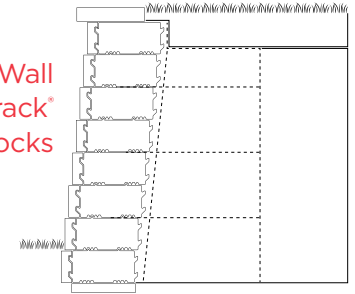

See pages 23–26 for more information about constructing higher walls.



TYPICAL ASSEMBLY

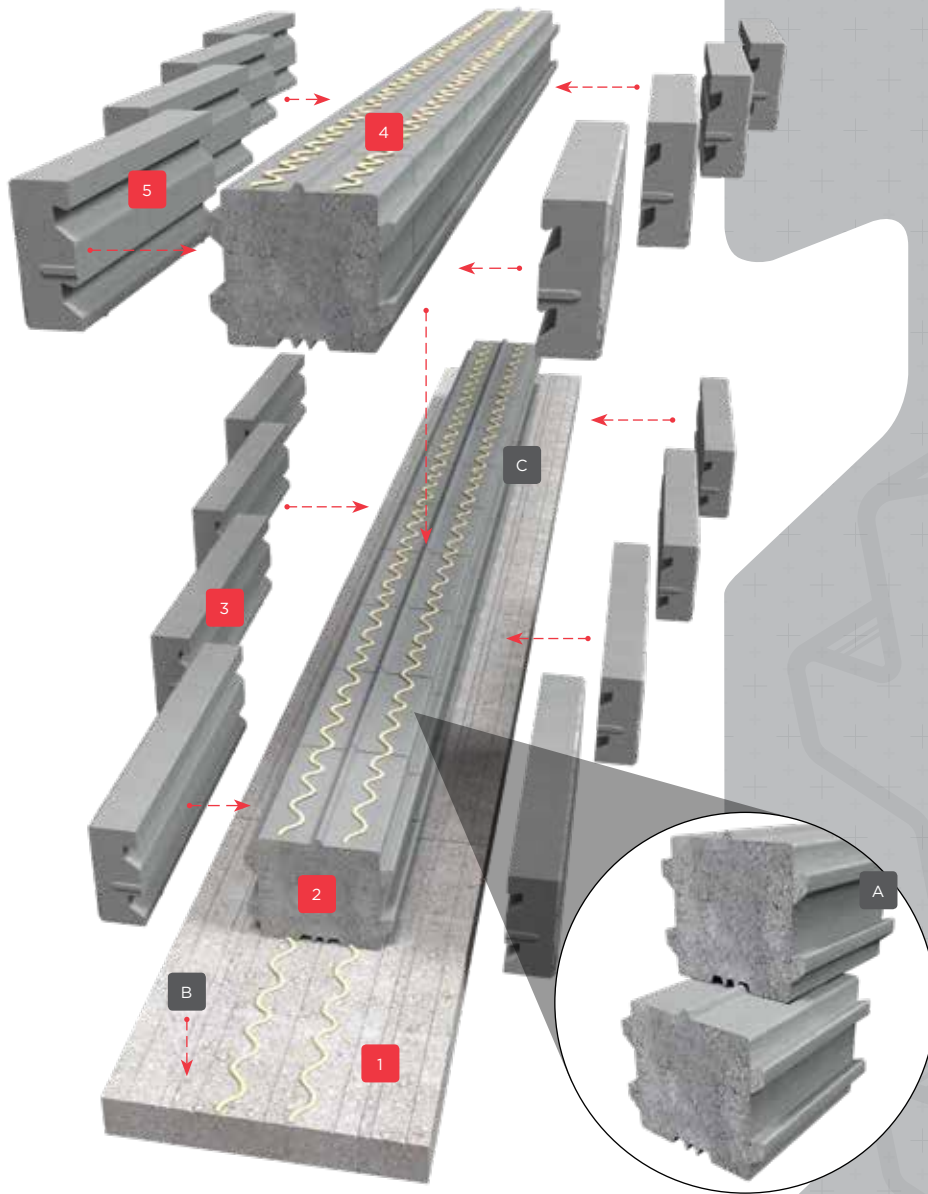

- 1 U-Cara **must** be installed on a hard surface. We recommend Unilock Universal Base Units placed over a compacted bed of gravel.
- 2 Position and glue the first row of Standard Sure Track® Backer Blocks onto the Universal Base Unit using the alignment grooves to help keep your line straight.
- 3 Always position U-Cara Fascia Panels onto the backer blocks **before** glue sets. This will allow you to easily adjust wall straightness with a straight-edge or stringline. Avoid cutting backer blocks by spacing them apart as required. The fascia panels will cover up any gaps. **Important:** Large Sure Track Backer Blocks do not require adhesive between rows. Only use adhesive between Standard Sure Track Backer Blocks when installed in the vertical position. No adhesive is required in the setback position.
- 4 Position and glue subsequent rows of backer blocks onto the previous course, staggering the joints. The bottom channels of the block will allow for construction of vertical or setback walls.
- 5 After placing a row of glued backer blocks, hang the U-Cara Fascia Panels before the adhesive has cured making minor alignment adjustments easier.

TIPS

A By offsetting the key and channel connection, you can create a 5.5 degree battered wall for additional strength.

B Use the factory stamped grooves in the Universal Base Unit to help maintain the alignment of your first row of backer blocks.

C Backer blocks can be conveniently spaced apart to make up differences in wall lengths. The spaces are hidden by the panels. Use filter fabric behind single sided planter walls.



90° CORNERS

- 1 Corners are generally constructed with Large Sure Track® Backer Block units. (See Fire Pits on page 22 for an alternate method.)
- 2 Prepare several large backer blocks by removing both top keys with a mallet and chisel. Then, snap Sure Track Corner Inserts into one side of the corner backer block.
- 3 Position and glue the first corner backer block to the base unit.
- 4 Position and glue large or standard backer blocks in each direction from the corner unit until you reach your next corner, pillar or wall. Before the glue sets, position and glue a U-Cara Closed-End Corner Panel onto the backer blocks.
- 5 Complete each corner with a U-Cara Standard Half Fascia Panel (provided in the corner bundle). Position these half units on the opposing side against the closed end of the corner panel.
- 6 Use a large square to ensure your corner is square.
- 7 Reverse the position of the large backer block every other row. Position and glue this assembly carefully.

Note: Closed end panels come bundled with 4 panels that close on the right and 3 that close on the left (per layer). Keep this in mind when deciding which panel should be used first on a corner or pillar.

TIPS } **A** Horizontally adjustable Sure Track inserts simply “snap” into molded channel.

} **B** Backer blocks can be conveniently spaced apart to make up differences in wall lengths.

Remove alignment keys from corner backer blocks.

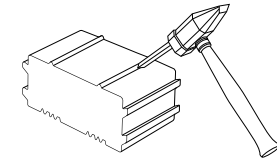
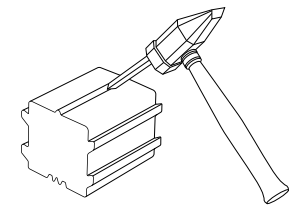
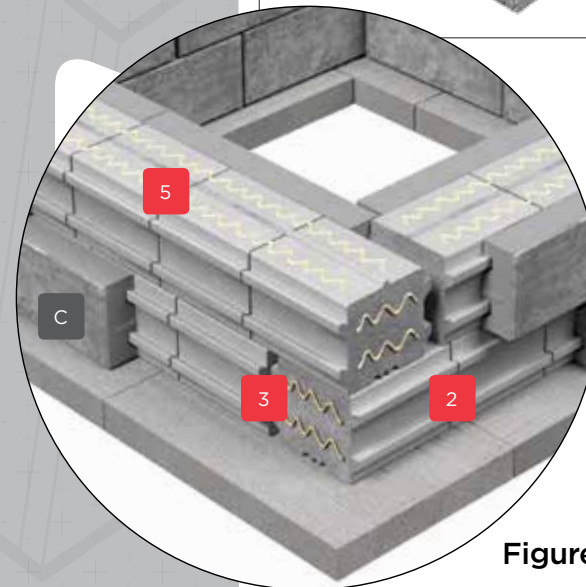
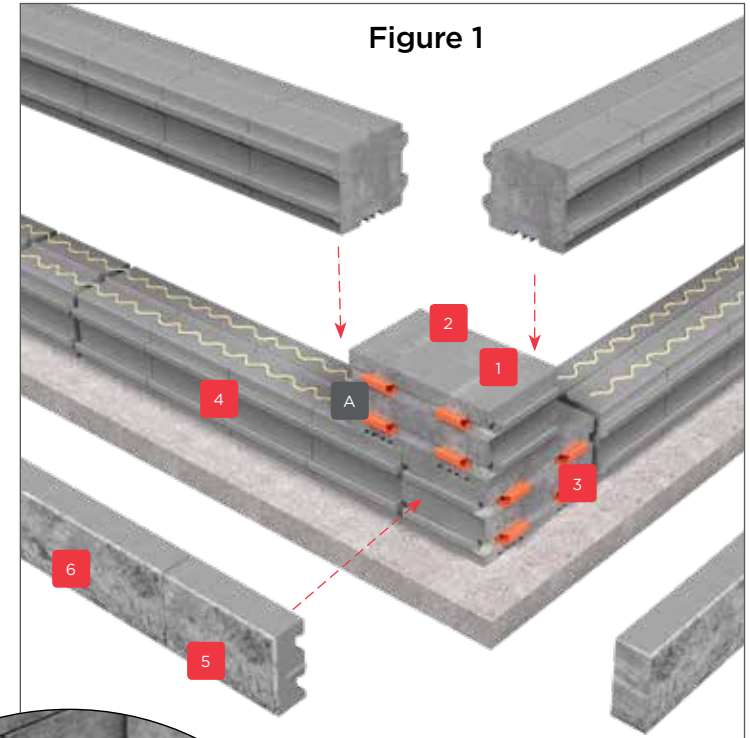

Figure 1



Corners can be constructed by “lapping” Large Sure Track backer Blocks (Fig.1) or Standard Backer Blocks (Fig. 2)

Figure 2

Removal of alignment key from backer blocks is required to accommodate crossing layers.

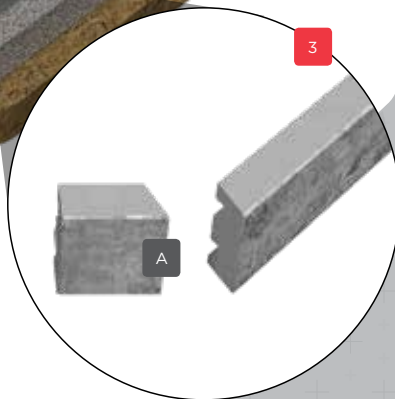
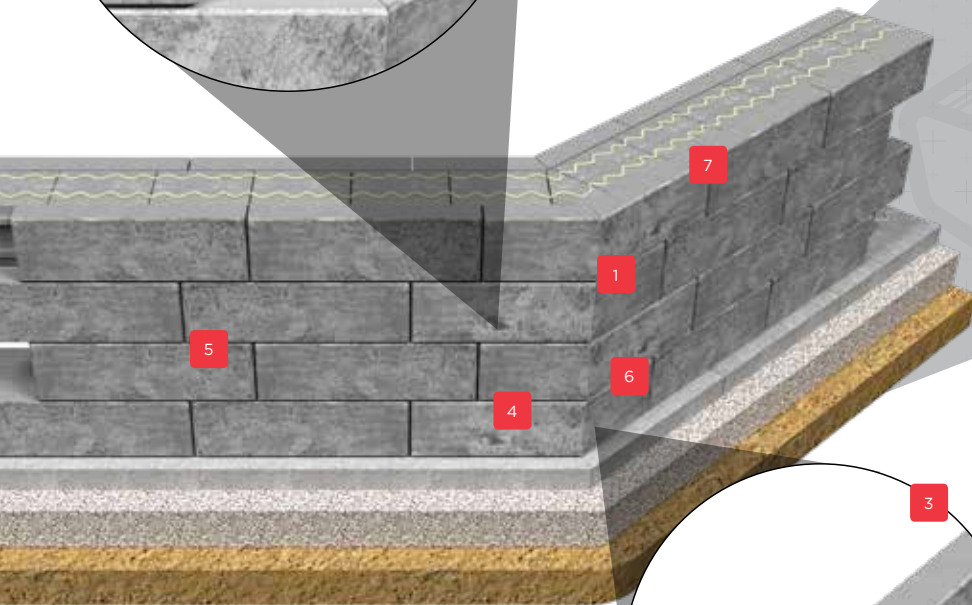
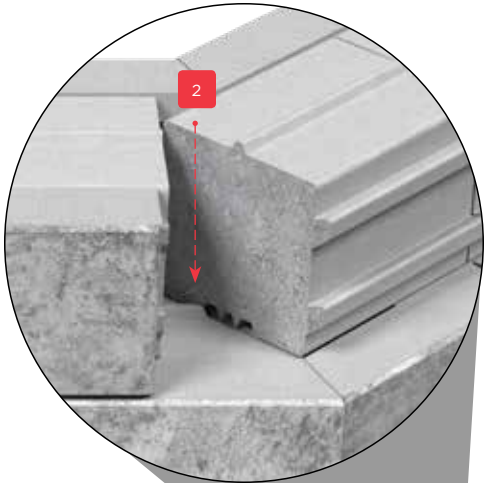
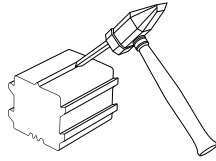

45° CORNERS

- 1 Whether you are constructing 90 or 45 degree corners, corners should always be constructed first.
- 2 When constructing a 45 degree corner, backer blocks will overlap every other row which will require the removal of any interfering top keys.
- 3 Cut the ends of U-Cara Fascia Panels and standard half panels on a 45 degree angle as shown.
- 4 It is a good practice to glue any angular cut backers or panels for additional strength.
- 5 When starting each course, always make sure to stagger the backer block joints.
- 6 Begin each course with the corner backers and corner panels.
- 7 Repeat steps 4 through 6 until desired height is reached.

TIPS | **A** For optimal structural and visual integrity, use concrete adhesive wherever possible between components.



CURVED WALLS

- 1 Always construct walls on Universal Base Units. Prepare 2 Standard Sure Track® Backer Blocks per panel length by removing the top alignment keys.
- 2 For single-sided walls, you only need fascia panels on one side of the backer blocks. One panel mounts on to two standard backers. No cutting of backers or panels is required.
- 3 For double-sided walls, you will need to order enough fascia panels to cover both sides. Inside radius panels must be cut to a length that will achieve your desired radius.
- 4 Min. radius (r) = 8 ft (2 m)
Inside panel length 8 ft r = 16.75" (42.5 cm)
Max. curved wall height = 24" above grade
- 5 When constructing two-sided curved walls, fill any voids between backer blocks with gravel to prevent light from showing through.

Removal of alignment key from top of all backer blocks is required to accommodate the radius.

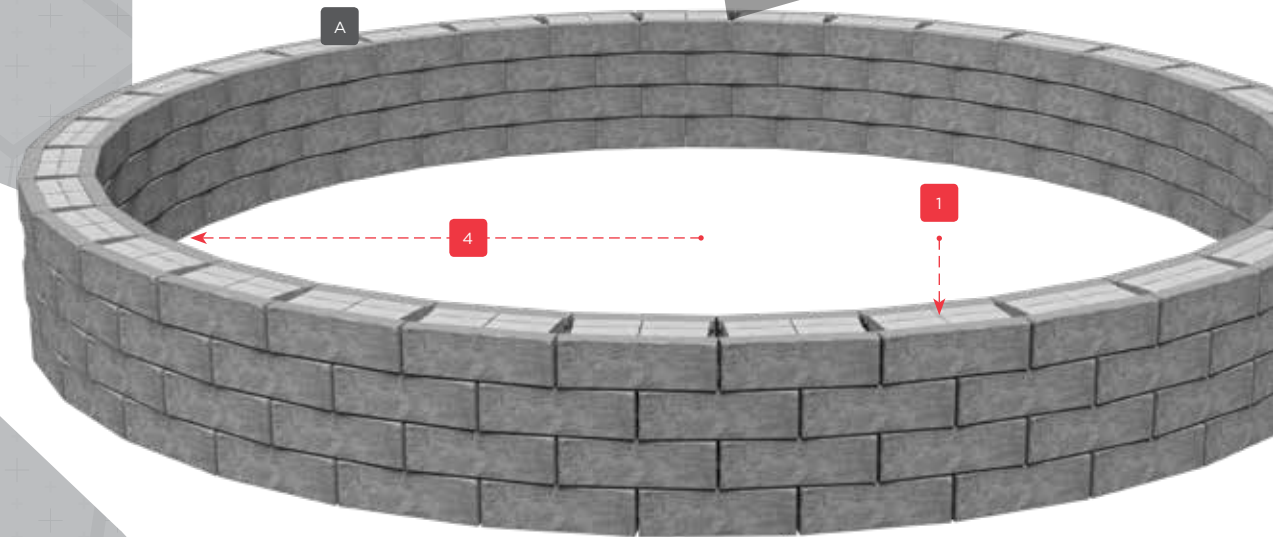
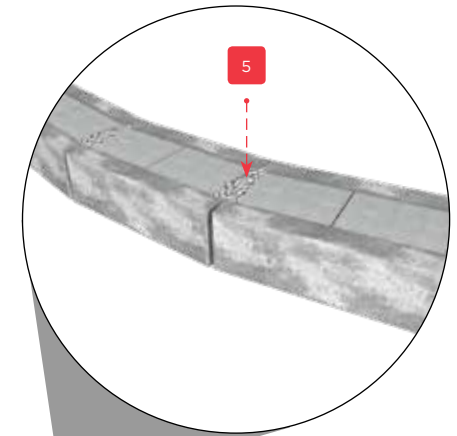
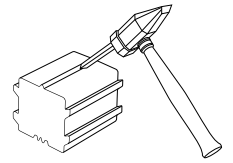

TIPS } **A** Adhesive is required to secure curved walls. You will need approximately one 10 oz. tube for every 5 feet of wall.

Remove alignment key from top row of backer blocks (optional).

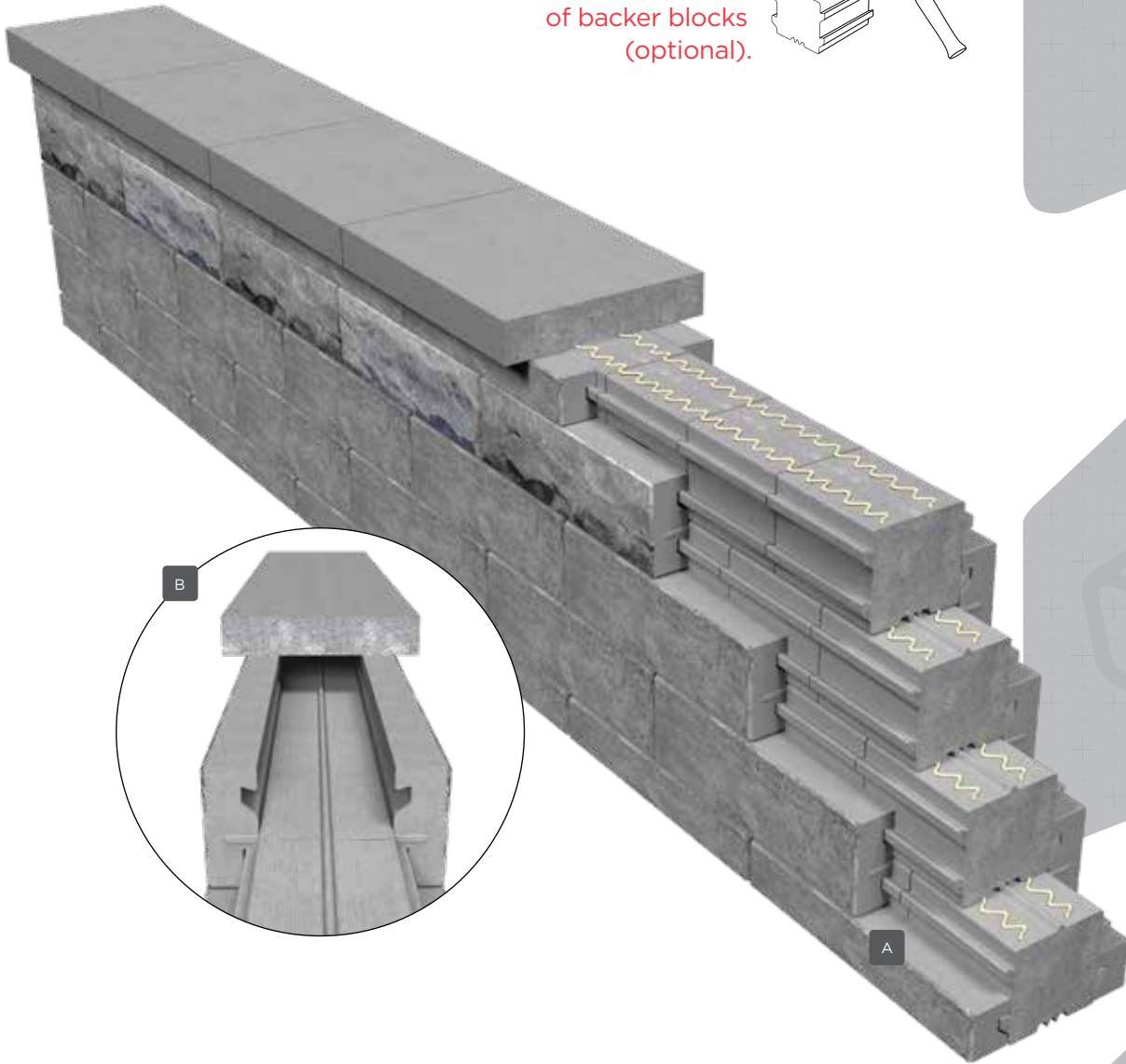
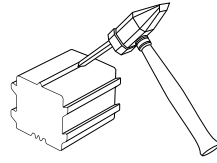

SURE TRACK OPTIONS

(VERTICAL WALLS ONLY)

Sure Track Backer Blocks offer various options for positioning U-Cara Fascia Panels. Fascia panels can be placed anywhere and on any track vertically or horizontally. This can only be done when the backers are stacked vertically.

Lock-Bonding

When a fascia panel straddles two courses of backer blocks, the wall will automatically be strengthened by a mechanical connection called, "lock-bonding".

TIPS

A Straddling the backer blocks with the fascia panels will require the first row of panels to be cut length-wise as a starter unit. Keep the cut off piece to use for the last row, just under the coping, or choose option B.

B In order to create a utility channel for electricity, gas or irrigation, simply install a full panel as the last row and then cap with coping. Use liberal amounts of concrete adhesive and always secure your work so that panel will not shift before curing.



SEAT WALLS

- 1 Universal 14" x 19" Coping (1.75" overhang each side)
- 2 U-Cara Fascia Panels (on both sides)
- 3 Patio or Lawn
- 4 Paver Bedding Course 1/4" Clear Chip Stone (ASTM No. 8 or 9)
- 5 4"-6" of 3/4" Clear Stone Base (ASTM No. 57)
- 6 Unilock DriveGrid™
- 7 4"-6" of 3/4" Clear Stone Base (ASTM No. 57)
- 8 Universal Base Unit
- 9 Native Subsoil

TIPS | **A** Comfortable seat walls are typically 16-18" from patio floor to top of coping.

Remove alignment key from top row of backer blocks.

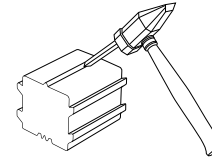

Seat Wall Side Elevation

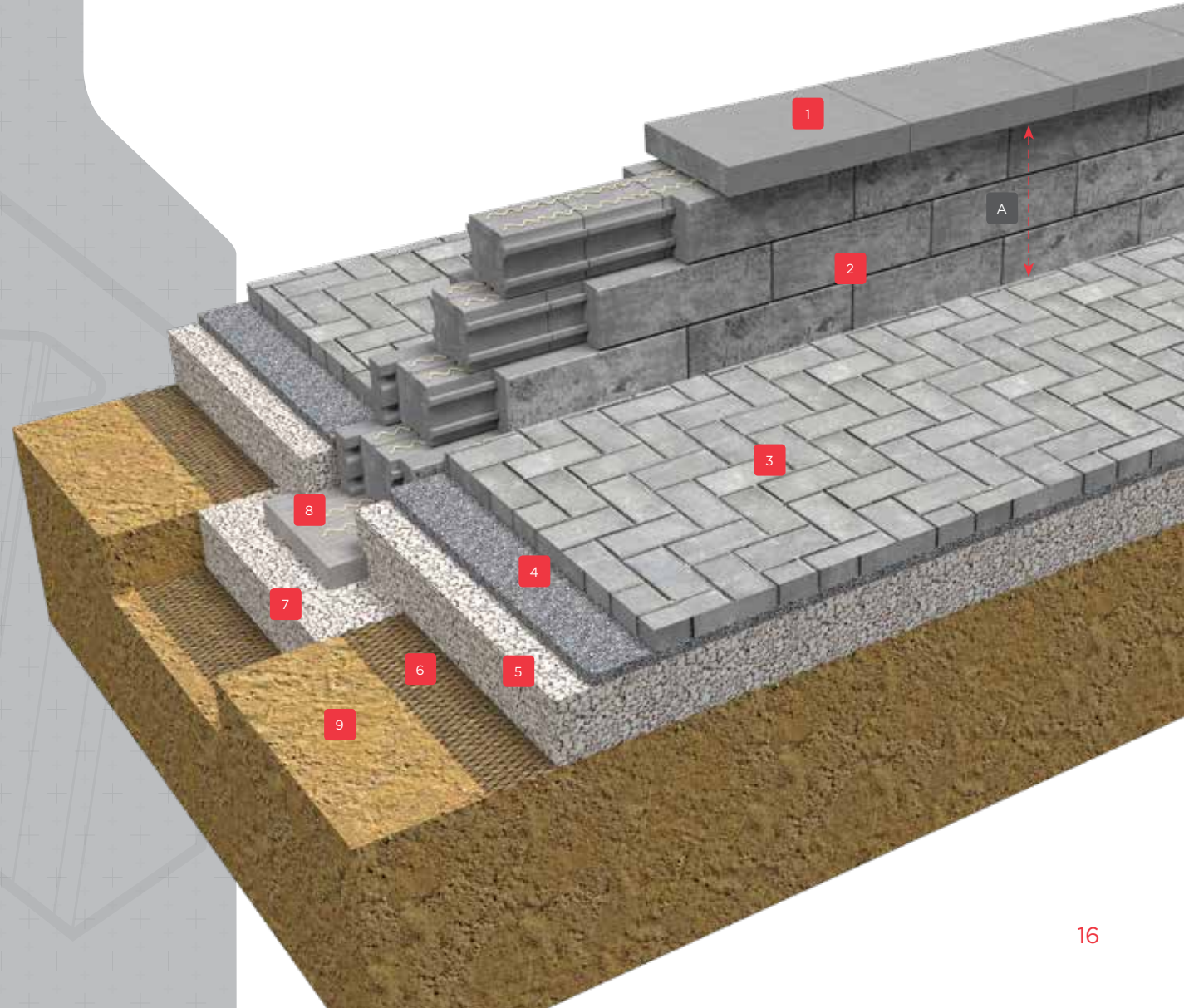
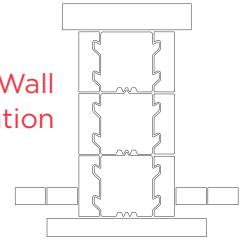

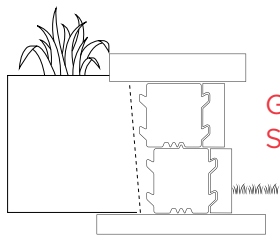

Garden Borders
Side Elevation

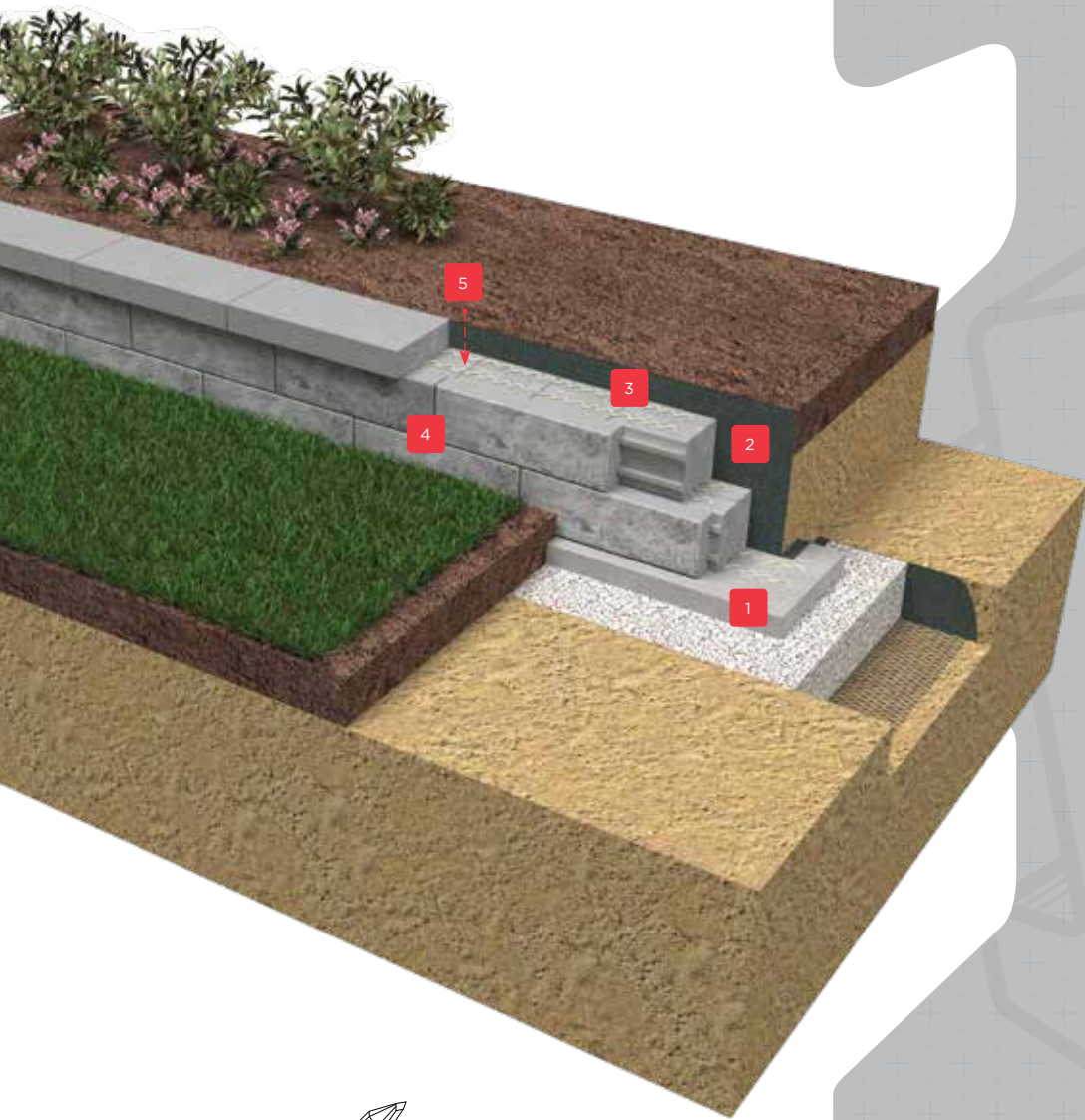

GARDEN BORDERS

The combined thickness of a Standard Sure Track® Backer Block and a fascia panel is less than 9" deep, making the U-Cara Wall System ideal for small garden borders or self-standing planters.

- 1 Install Universal Base Units on a 6" gravel base ensuring they are perfectly level. Use DriveGrid™ under gravel for added stability.
- 2 Use a permeable filter fabric to separate the soil from the back of the wall.
- 3 If stacked vertically, standard backer blocks should be glued.
- 4 Attaching fascia panels to backers will help align the backers as you go. **Note:** In frost-prone areas, applying some glue between the bottom of the fascia panels and the universal base unit is good practice.
- 5 Always glue coping to the top of your backers after removing the alignment key.

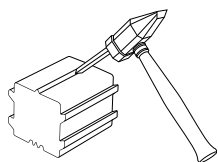

Remove alignment key from top row of backer blocks.

TIPS → **A** For narrow planters consider using U-Cara Fascia Panels as coping.



STEPS

Building steps with U-Cara is like building a set of miniature single-course walls, one behind the other.

- 1 Universal Base Units should be used to construct steps quickly and securely.
- 2 Steps are constructed using Large Sure Track® Backer Blocks with the top keys removed. Position and glue an entire row of the backer blocks to the Universal Base Unit. Be sure to leave enough room to adhere fascia panels onto the front of the backers. Then, the assembly of backers and fascia can be pushed forward to meet the previous coping or paver surface. The adhesive under the backers will facilitate the sliding forward.
- 3 Complete each step by gluing the coping to the top of the large backer units. An overhang of 1.5" (3.8 cm)–2" (5 cm) is recommended.
- 4 For each consecutive step, install another row of Universal Base Units flush to the top of the backers of the previous step.
- 5 In order to attach panels on an exposed end, simply snap in the Sure Track Corner inserts and attach a U-Cara Fascia Panel.

TIPS

Visit unilock.com to watch the "How to Build Steps" video.

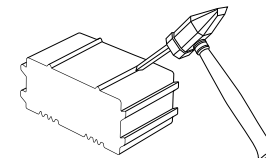
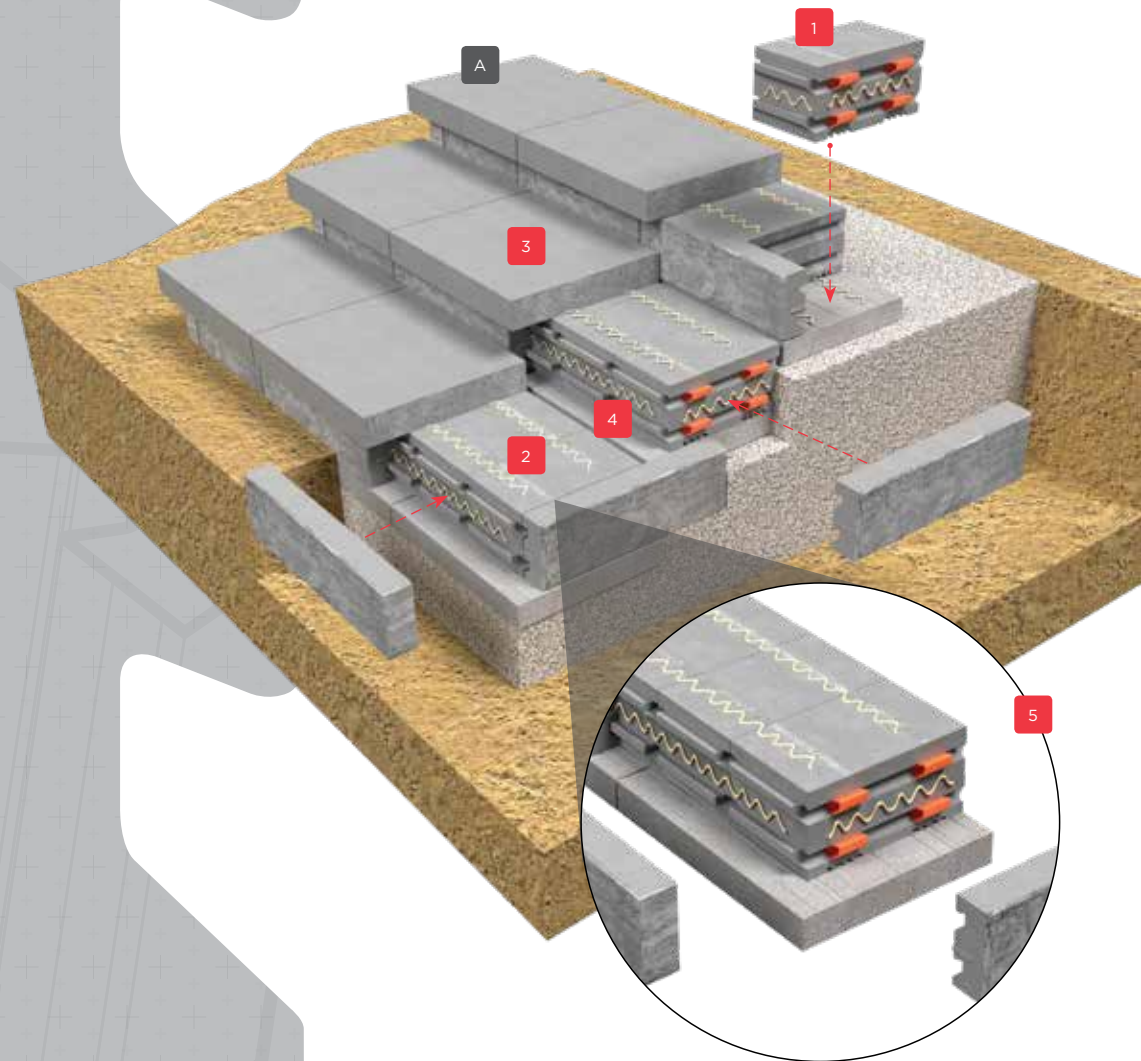
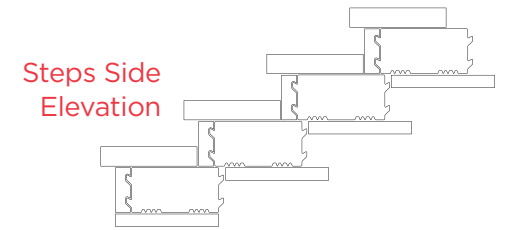

Remove alignment key from top row of backer blocks.

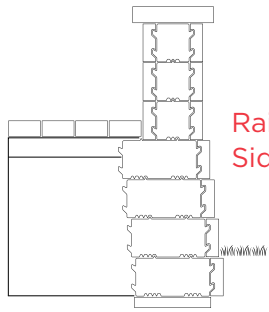

Raised Patio
Side Elevation

Note: This wall may require a railing. Always follow prevailing building codes.

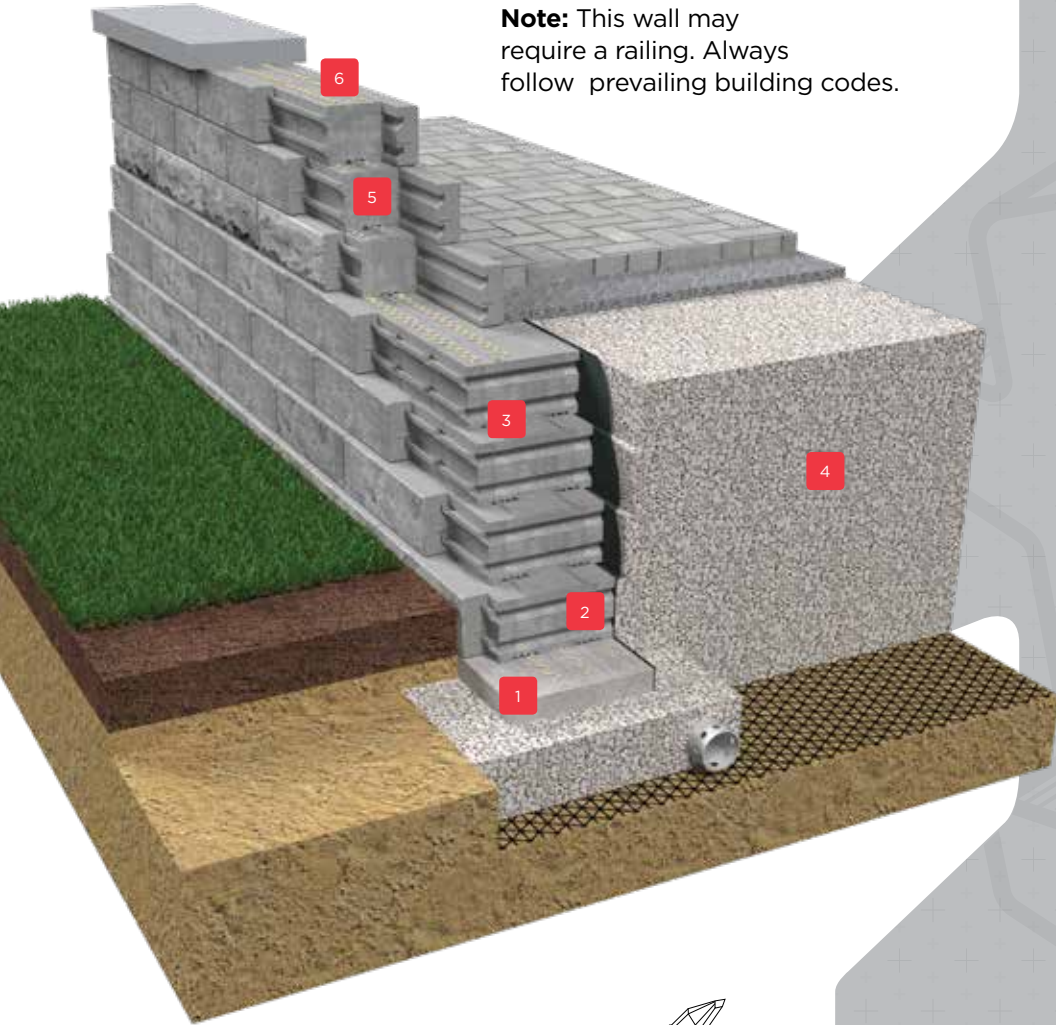

Remove alignment key from top row of backer blocks.

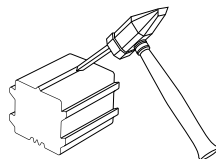

RAISED PATIO

- 1 Install Universal Base Units on a 6" gravel base, ensuring they are perfectly level.
- 2 Adhere the first row of Large Sure Track® Backer Blocks onto the Universal Base Units. (Optional) Use the grooves impressed onto the surface of the base unit to maintain block alignment.
- 3 Continue to install subsequent rows of backer blocks making sure you horizontally offset each row by one half block. You may need to cut one backer in half every other row. We recommend installing backers in the "set-back" position for increased wall strength.
- 4 Back fill as you go (max two layers of U-Cara) with 3/4" clear stone (ASTM No. 57). A layer of filter fabric is recommended directly behind the block to prevent any aggregate from migrating through any openings. **Note:** Geogrid (optional) may also be used to reinforce walls (See page 25).
- 5 When you reach patio-level height and your plan calls for a seat wall around the perimeter of the patio, you can transition over to standard backer blocks and clad both sides with fascia panels.
- 6 In order to attach coping to the top of the seat wall, remove the top key on the top row.



PILLARS

ASSEMBLY

Pillars should be constructed on 6" (15 cm) to 12" (30 cm) of clear open graded gravel. The pillar embedment should never be less than 12" (30 cm) below grade.

- 1 Install 4 Universal Base Units on a compacted gravel base. These base units must be level.
- 2 Before constructing the pillar, prepare enough large backers by removing the "front" top key of each block. Using concrete adhesive, adhere 4 large backer blocks to the base units ensuring that the corner inserts face outwards.
- 3 Position 4 "left" panels on the Sure Track® Rails. Use a carpenter's square to square up the first layer of corner backer blocks and fascia panels.
- 4 To begin the second layer, adhere 4 corner backer blocks in an offset "log cabin" layout.
- 5 Position 4 "right" fascia panels on the rails. Use a carpenter's square to square up the first layer to the second layer.
- 6 Continue each layer until you have reached the desired height.
- 7 Adhere a coping unit to the top.

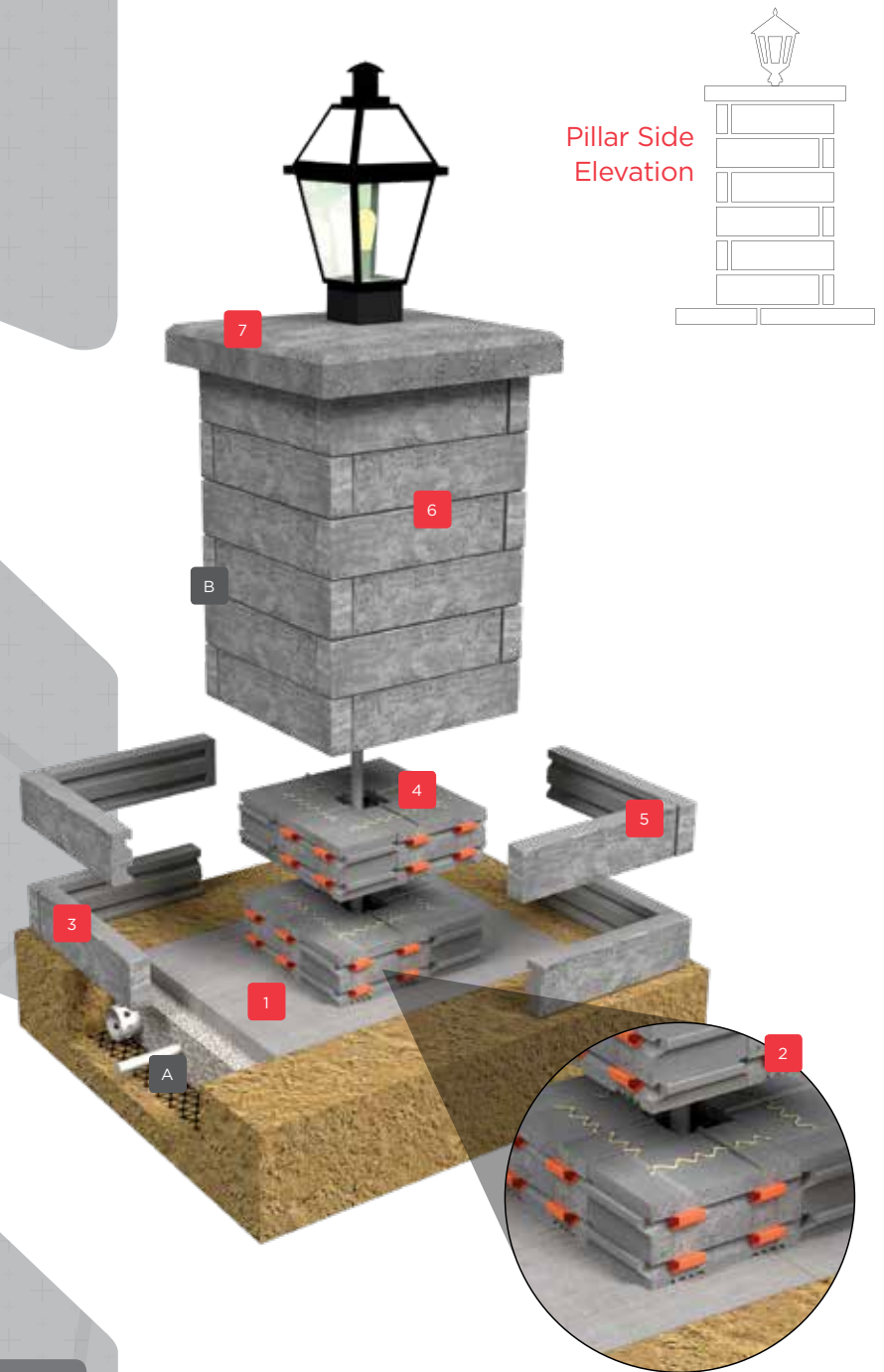

TIPS **A** For lamp posts, be sure to run conduit and electrical wire to the pillar. (All electrical work must be done by a qualified electrician).

B Closed end corner fascia panels come in "lefts" and "rights". Alternate between lefts and rights every other course.

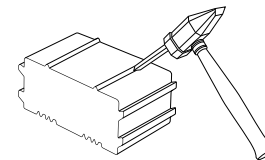

Remove front alignment key from top of each backer block.

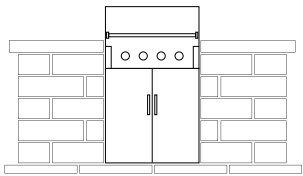

Grill Island
Front Elevation

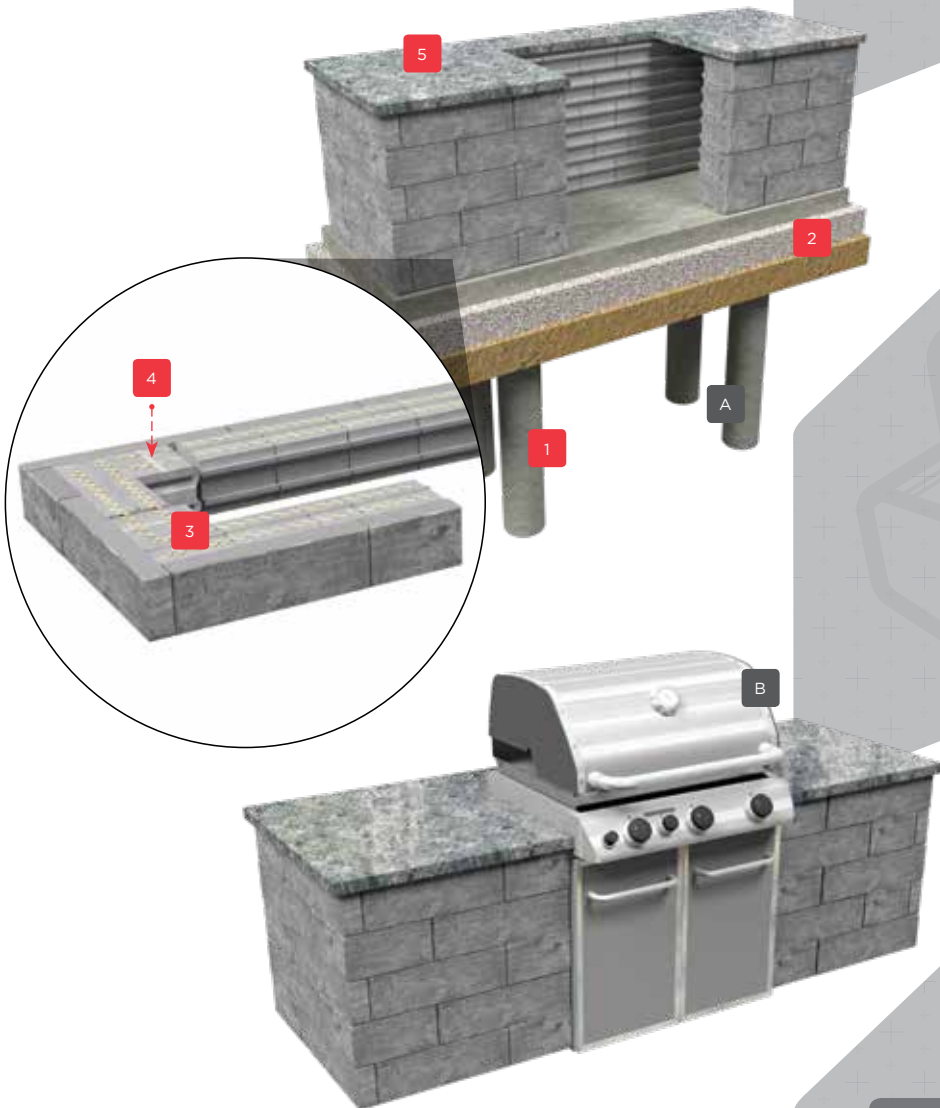

Remove alignment
key from top row of
backer blocks.

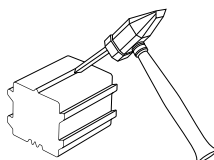

GRILL ISLAND

- 1 Grill Islands and other larger features should be constructed on a concrete pad supported by 10" diameter concrete piers seated below the frost line. Space piers 6' apart and place a wire mesh or rebar across the piers prior to pouring the 6" thick pad.
- 2 Ensure there is also 6" of 3/4" open-graded stone gravel under the pad.
- 3 Position Large Sure Track® Backer Blocks at the corner locations and fill in between with standard or large backers. If you are constructing the island within the panel dimensions, attach the panels to the backer blocks as you go for precise alignment. You will need to insert 4 Sure Track Corner Inserts into the side channel so you can hang a panel. We recommend that you glue corner fascia panels to the backer blocks for additional strength.
- 4 In order to "log cabin" the corners, remove the top key and repeat step 3 with the corner backer starting in the opposite direction.
- 5 Install precast or granite counter top.

TIPS

A Install gas lines right after drilling in the piers and before pouring the concrete pad.

B Order the grill in advance of constructing the grill island so that you will know the exact dimensions for the opening in the grill island and the counter top.



FIRE PIT

- 1 Install 8 Universal Base Units on a minimum 6" gravel base as shown, ensuring they are perfectly level.
- 2 You will need to prepare 12 Standard Sure Track® Backer Blocks by removing the top key. Construct the corners by creating a butt joint with the standard backer blocks as shown. **Note:** Do not use the large backer blocks with the plastic inserts because the inserts are not designed for high heat applications.
- 3 Position and glue the first row of standard backer blocks as shown. Only use construction adhesive rated for high-heat applications (A 1200°F minimum rating is recommended).
- 4 Adhere U-Cara Corner Fascia Panels on the outside and inside of the fire pit using the same construction adhesive. Position and glue the next row of backer blocks onto the first row of backers. Create a "log cabin" corner as shown.
- 5 Repeat for consecutive rows until the desired height has been reached.

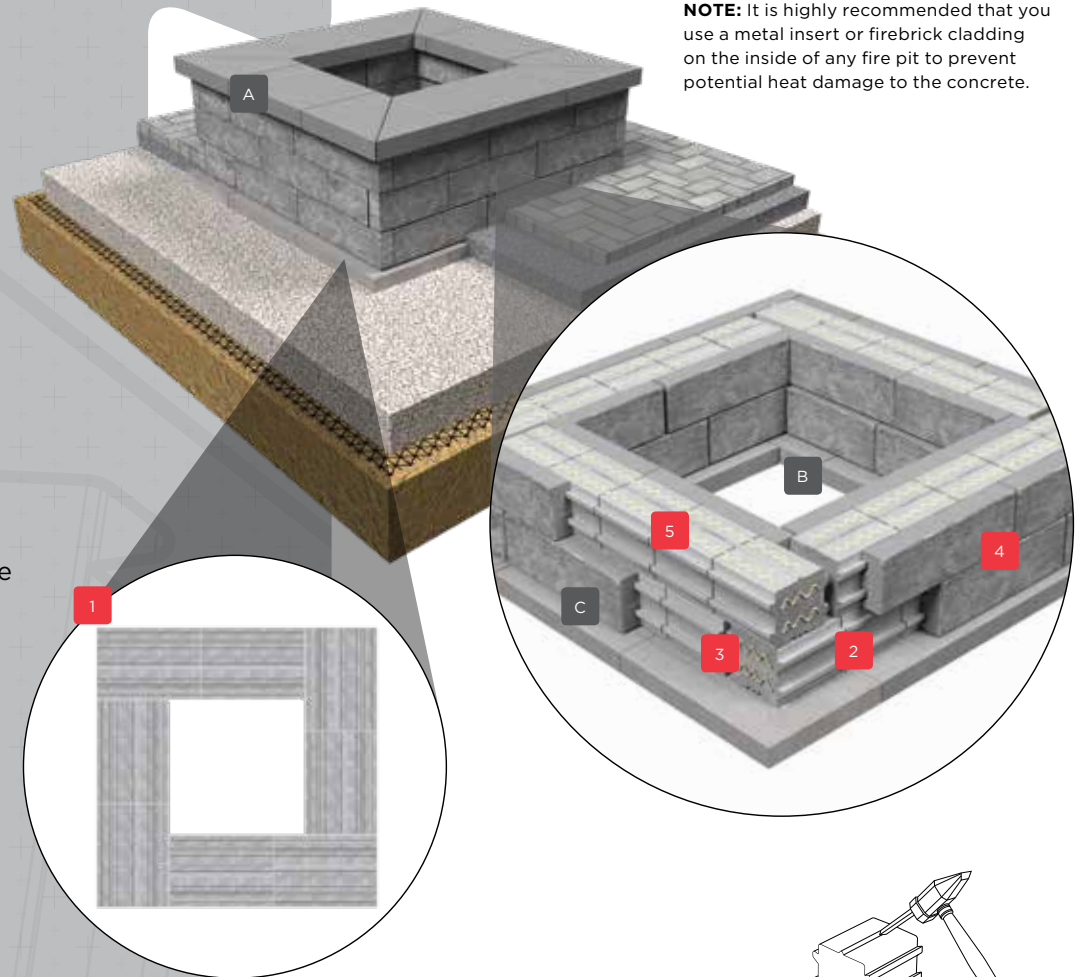

Fire Pit Side Elevation

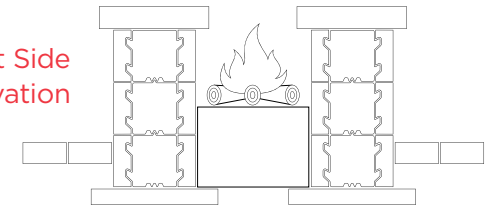

NOTE: It is highly recommended that you use a metal insert or firebrick cladding on the inside of any fire pit to prevent potential heat damage to the concrete.

TIPS

A Only use construction adhesive rated for high-heat applications. A 1200°F minimum rating is recommended.

B If you are building a gas fire pit, make sure that you run your gas line to the center of the pit area before installing the base units.

C Always apply adhesive between the bottom of the first row of fascia panels and the Universal Base Unit.

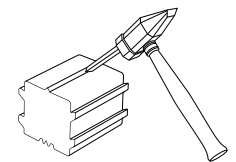

Remove alignment key from top row of backer blocks.

GRAVITY WALL

BACKFILL TYPE "A"

Load Assumptions



Wall Alignment	Exposed Wall Height (ft/m)	Max Total Wall Height (ft/m)	Exposed Wall Height (ft/m)	Max Total Wall Height (ft/m)
-	(ft/m)	(ft/m)	(ft/m)	(ft/m)
0° Vertical	1.7/0.52	2.2/0.67	1.7/0.52	2.2/0.67
5.5° Battered	2.2/0.67	2.7/0.82	2.2/0.67	2.7/0.82

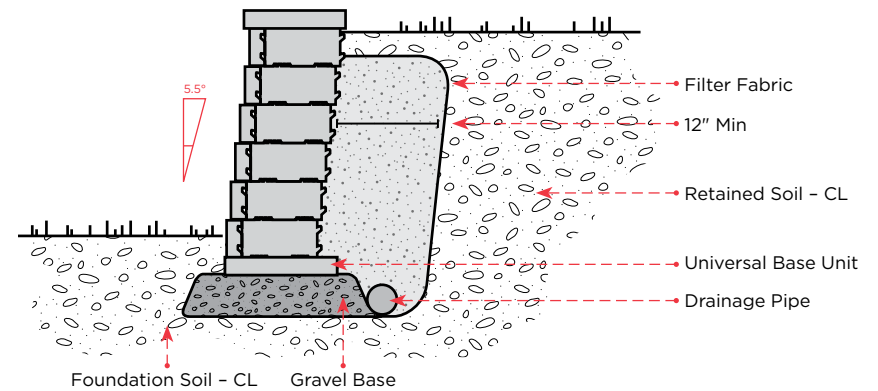

Soil Assumptions

Soil Condition	Description	0-degrees	Unit Weight (g-lb/cu.ft)
Drainage (Min. 12"/0.3m)	GP Free Draining Gravel, max 5% fines	-	-
Retained	CL Inorganic Clays, low-med plasticity	28	125
Foundation	CL Inorganic Clays, low-med plasticity	28	125

Drainage to be Free Draining Material in accordance with NCMA recommendations. A minimum Embedment of 0.5 ft/0.15 m is required.

GRAVITY WALL

BACKFILL TYPE "B"

Load Assumptions



Flat | Pedestrian Load
(50psf/2.4kPa)

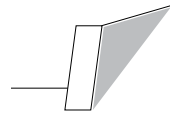

Slope | 3H:1V

Wall Alignment	Exposed Wall Height	Max Total Wall Height	Exposed Wall Height	Max Total Wall Height
-	(ft/m)	(ft/m)	(ft/m)	(ft/m)
0° Vertical	2.6/0.79	3.1/0.94	2.6/0.79	3.1/0.94
5.5° Battered	3.1/0.94	3.6/1.10	3.1/0.94	3.6/1.10

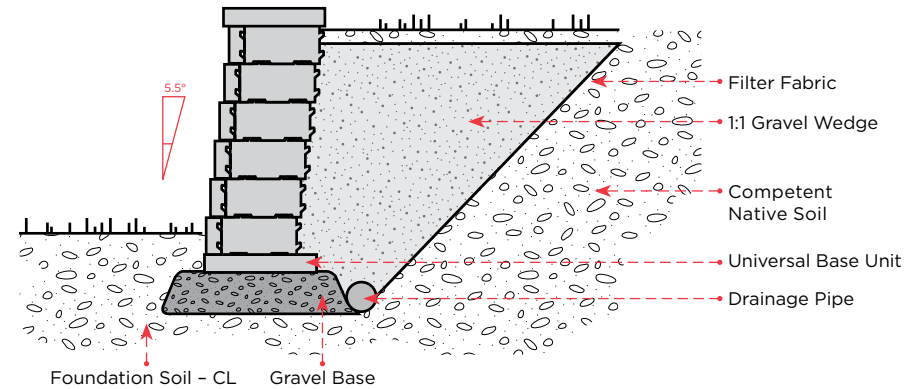

Soil Assumptions

Soil Condition	Description	O-degrees	Unit Weight (g-lb/cu.ft)
Drainage/Retained 1H:1V Gravel Wedge	GP Free Draining Gravel, max 5% fines	35	115
Foundation	CL Inorganic Clays, low-med plasticity	28	125

Drainage to be Free Draining Material in accordance with NCMA recommendations. A minimum Embedment of 0.5 ft/0.15 m is required.

GEOGRID REINFORCED

TYPICAL VERTICAL

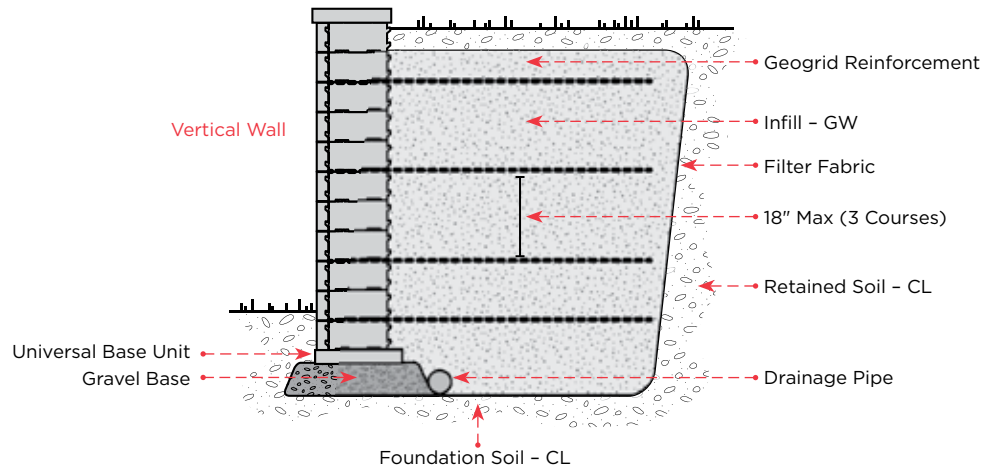

Soil Assumptions

Soil Condition	Description	0-degrees	Unit Weight (g-lb/cu.ft)
Infill (Reinforced)	GW Well graded gravel, gravel sand, max 5% fine content	35	140
Retained	CL Inorganic Clays, low-med plasticity	28	125
Foundation	CL Inorganic Clays, low-med plasticity	28	125

GEOGRID REINFORCED

TYPICAL BATTERED (5.5-DEGREE)

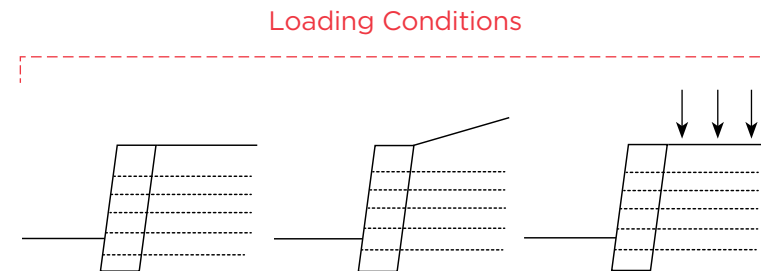
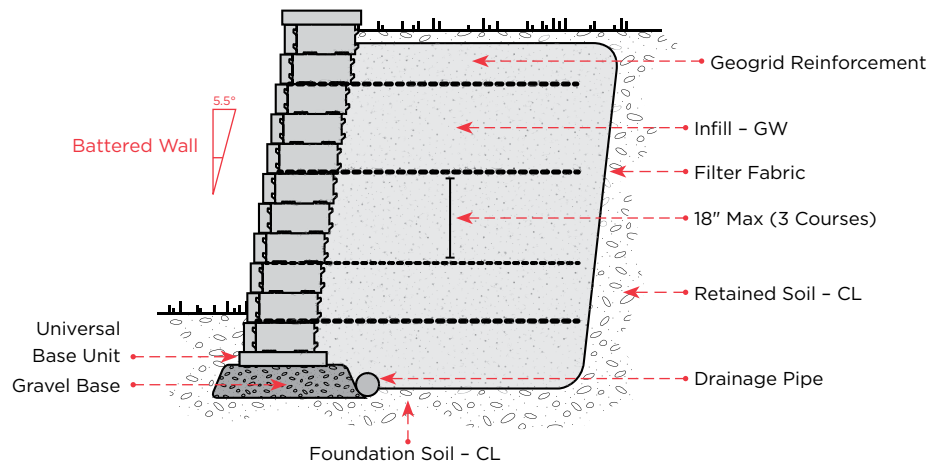

Geogrid Required (for Vertical or Battered Wall Installation)

Exposed Wall Height	Embedment	Total Wall Height	No. Geogrid Layers	Flat Pedestrian Load (50psf/2.4kPa)	Slope 3H:1V	Heavy Traffic (250psf/12kPa)
				Grid Length (ft/m)	Grid Length (ft/m)	Grid Length (ft/m)
(ft/m)	(ft/m)	(ft/m)				
3.2/0.97	0.5/0.15	3.7/1.12	2	4.0/1.22	4.0/1.22	4.0/1.22
3.7/1.12	0.5/0.15	4.2/1.27	2	4.0/1.22	4.0/1.22	4.0/1.22
4.1/1.27	0.5/0.15	4.7/1.42	3	4.0/1.22	4.5/1.37	4.5/1.37
4.6/1.41	0.5/0.15	5.2/1.56	3	4.5/1.37	4.5/1.37	4.5/1.37
5.1/1.55	0.6/0.17	5.6/1.72	3	4.5/1.37	5.0/1.52	5.0/1.52
5.5/1.68	0.6/0.19	6.1/1.87	4	5.0/1.52	5.5/1.68	5.5/1.68
6.0/1.82	0.7/0.20	6.6/2.02	4	5.0/1.52	5.5/1.68	5.5/1.68
6.4/1.95	0.7/0.22	7.1/2.17	4	5.5/1.68	6.0/1.83	6.0/1.83
6.8/2.09	0.8/0.23	7.6/2.32	5	6.0/1.83	6.5/1.98	6.5/1.98
7.3/2.22	0.8/0.25	8.1/2.47	5	6.0/1.83	7.0/2.13	7.0/2.13
7.7/2.36	0.9/0.26	8.6/2.62	5	6.5/1.98	7.0/2.13	7.0/2.13

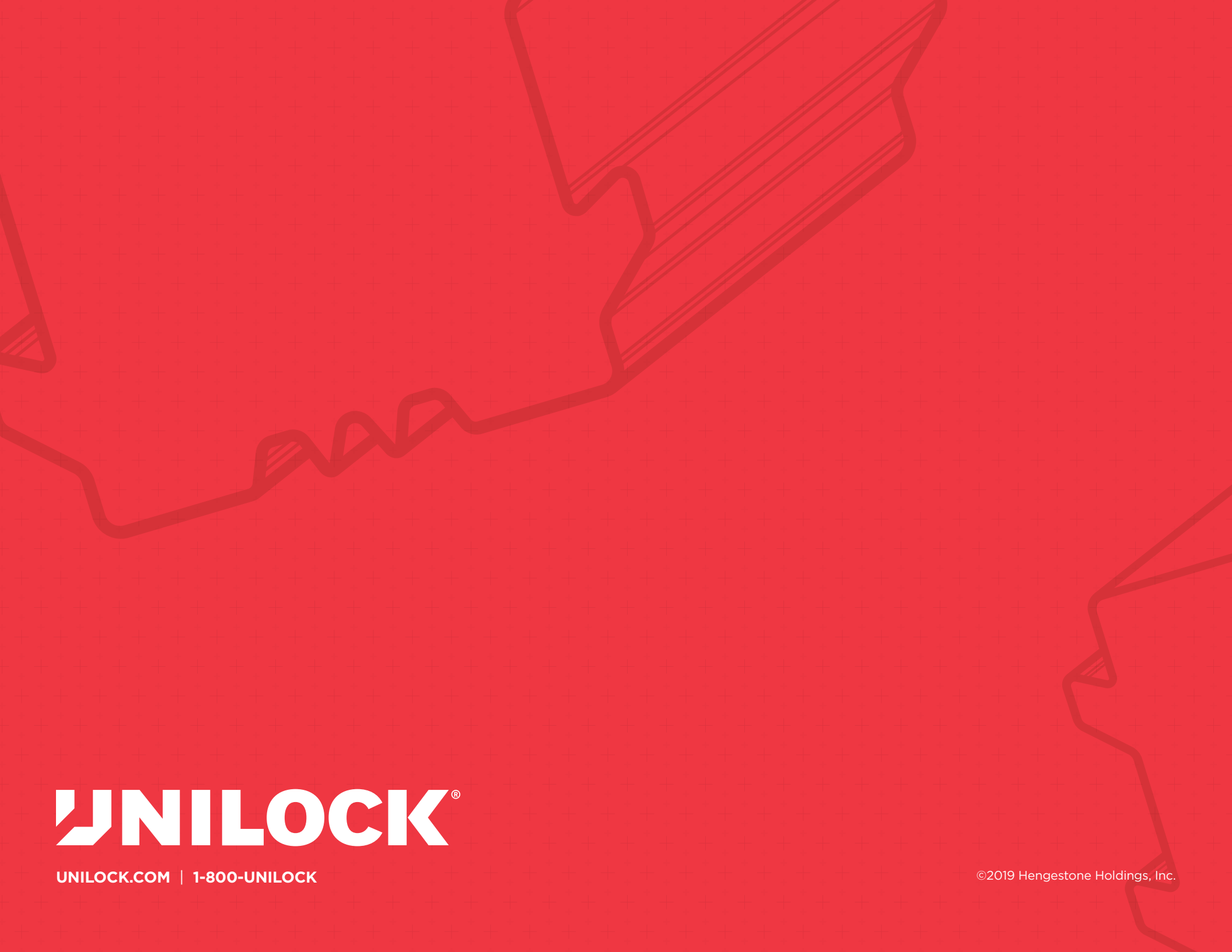

UNILOCK[®]

UNILOCK.COM | 1-800-UNILOCK

©2019 Hengestone Holdings, Inc.